

OFTEC TECHNICAL BOOK THREE PART 1 (DOMESTIC) DOMESTIC OIL STORAGE

Typical Integrally Bunded Steel Oil Storage Tank to OFS T200

(Diagram 2.2b)

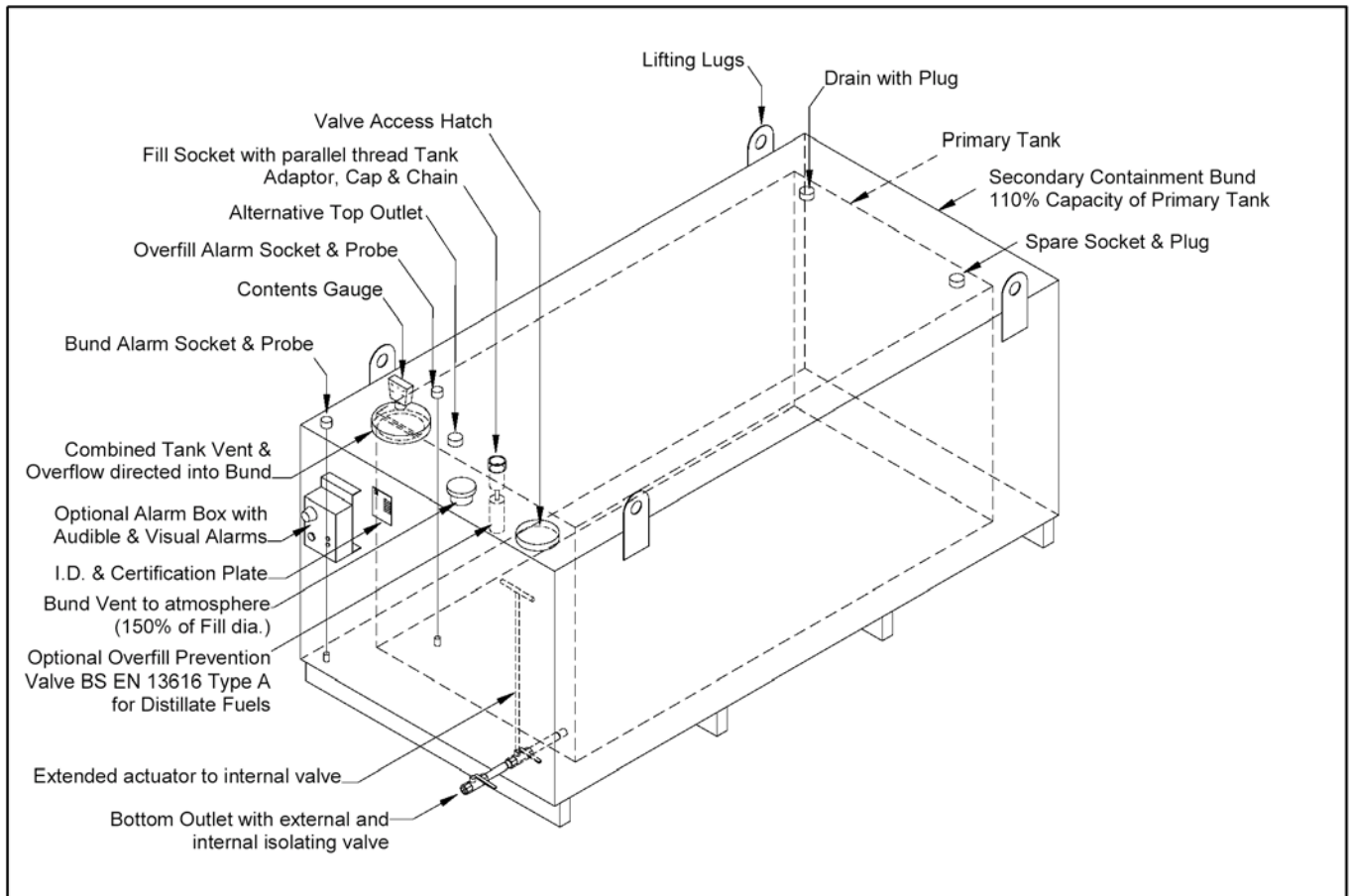

NOTE: 600mm diameter manway fitted to tanks over 3500 litres capacity.
 Optional bund sump box not shown.
 Optional bund inspection hatch not shown.
 Overfill prevention devices can either be Type A or B to BS EN 13616